

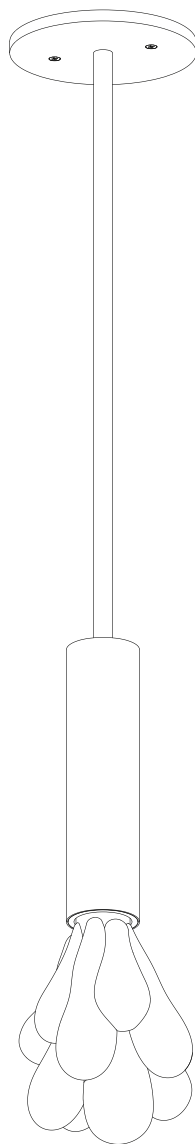

# DEW PENDANT

## Installation Instructions



**SkLO**

sklo.com

SkLO US 115 WEST NORTH STREET HEALDSBURG CALIFORNIA 95448 USA +1.707.385.2101 us@sklo.com  
SkLO EU VÁŽNÍ 488 500 03 HRADEC KRÁLOVÉ CZECH REPUBLIC +420.495.542.071 eu@sklo.com



# DEW PENDANT



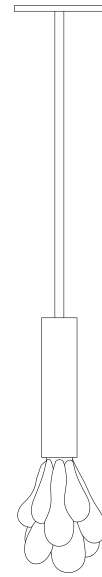

*Congratulations on your purchase of a SkLO Dew Pendant. This product must be installed in accordance with the applicable codes by a person familiar with the construction and operation of the product and the hazards involved, preferably a licensed electrician. Use a maximum 7W bulb.*

**When unpacking individual items and parts of the light fixture, make sure to lay them out on a protective surface that will neither mar the delicate metal finishes nor scratch the glass. Gloves (nitrile) are provided and must be worn during installation to avoid fingerprints on the finish of the exposed metal parts.**

*Your SkLO fixture will arrive with the hand-blown glass elements packed separately from the light fixture itself.*

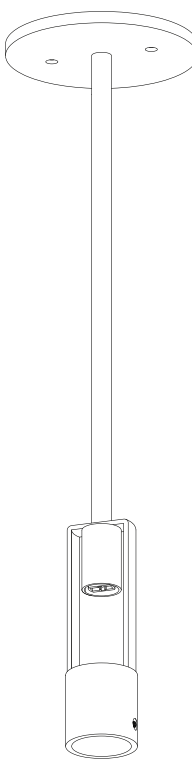

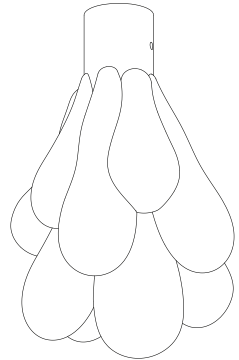
## CONTENTS:

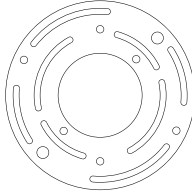
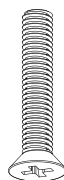
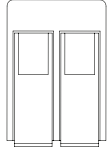
Canopy + stem + light fixture assembly	Additional stem segment (longer OAD lengths only)	Metal sleeve	Glass element	
				
1x	1x	1x	1x	1x
	Light bulb	Universal crossbar	Machine screw	Wire connector
				
		quantity varies	1x	2x
				2x



1. Carefully remove the two set screws in the bottom part of the assembly and set them aside (Figure 1a).
2. Install the supplied LED light bulb (7W Max) into the socket (Figure 1b). This fixture uses G9 sockets and light bulbs. The G9 is a bi-pin socket. Light bulbs are to be inserted and removed by pushing the bulb straight into the socket, and by pulling it straight out. The bulb, when inserted, should have a tight fit. Do not force the bulb. If there is resistance, check to make sure nothing inside the socket is bent or obstructing the bulb. Always turn off the power to the fixture when changing the bulb(s).
3. Slide the brass sleeve over the assembly. While holding it above the threaded holes, slide the glass diffuser into the bottom part of the assembly so that the holes in the glass align with the threaded holes in the brass and secure it in place with the two set screws. Thread the set screws just until they are aligned with the face of the assembly. Then carefully slide down the sleeve until it sits on the glass diffuser (Figure 2).
4. For lights with longer OAD lengths, the stem will be in multiple parts. Uncoil the electrical wiring at the top of the fixture and carefully pass the wires through each stem as you fasten them together and then the canopy at the end. To connect the stems, thread the open end of each stem onto the exposed nipple of the other (Figure 3).
5. Install the universal crossbar (provided) to the recessed electrical box with the 8/32 thread screws so that the 8/32 threaded holes spaced 2 3/4" on-center on the crossbar match the desired orientation of the fixture based on the countersunk holes in the canopy (Figure 4).
6. Connect the exposed leads of the fixture to the exposed leads in the electrical box, following the wiring diagram and using the provided wire connectors. Attach the ground (TE) wires to ground (TE) wires of the light fixture, phase 1 (L1) to phase 1 (L1) of the light fixture, neutral (N) to neutral (N) of the light fixture (Figure 5). Please note the number and type of wire connectors may vary.
7. The canopy installs directly to the crossbar. The back of the canopy is recessed to fit over the crossbar and to sit flush against the ceiling finish surface. Take care that no electrical cables or connections are exposed where the canopy meets the ceiling. Fasten the canopy by screwing the two provided 8/32 thread machine screws directly into the 8/32 threaded holes spaced 2 3/4" on-center on the crossbar through the countersunk holes provided in the canopy, making sure that the canopy sits flush against the ceiling finish surface (Figure 6). Take great care when installing machine screws so that tools do not slip and scratch the canopy finish, or damage the exposed screw head slots.



1a.

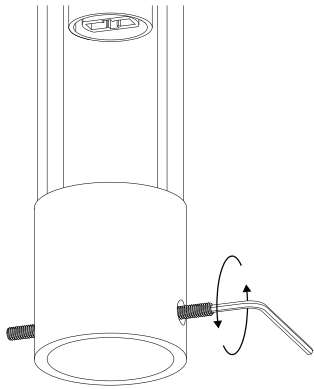

1b.

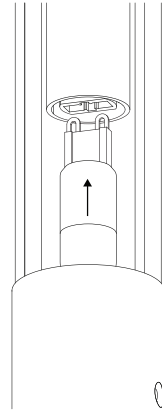

2.

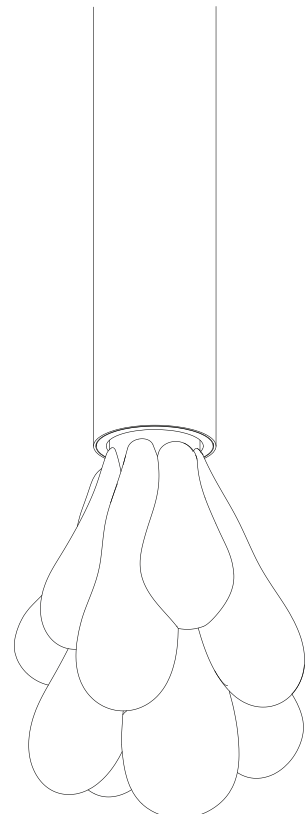
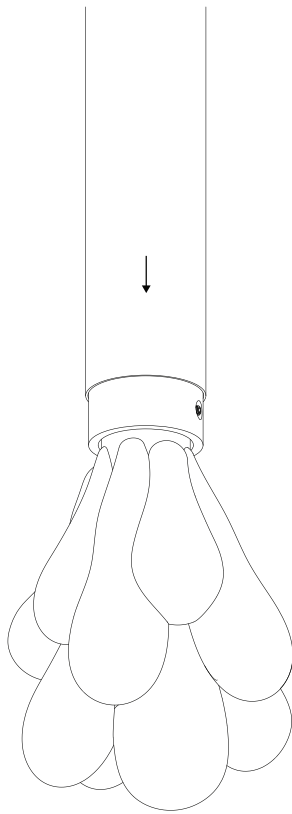
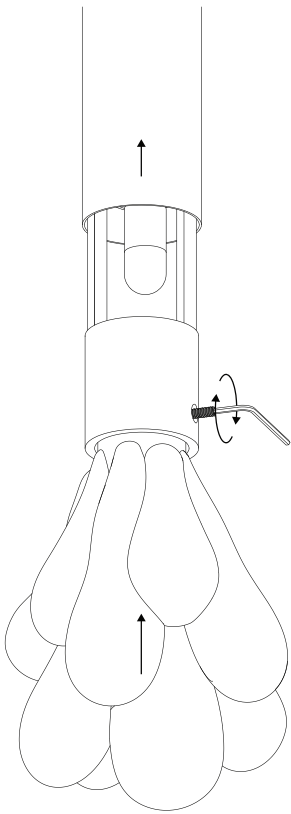

3.

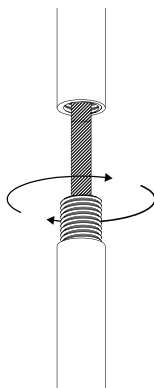



4.

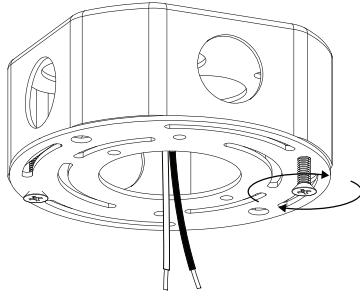

5.

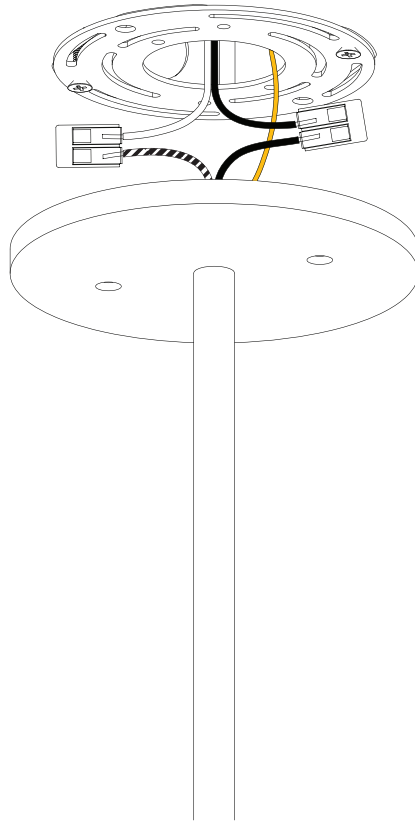

6.

